

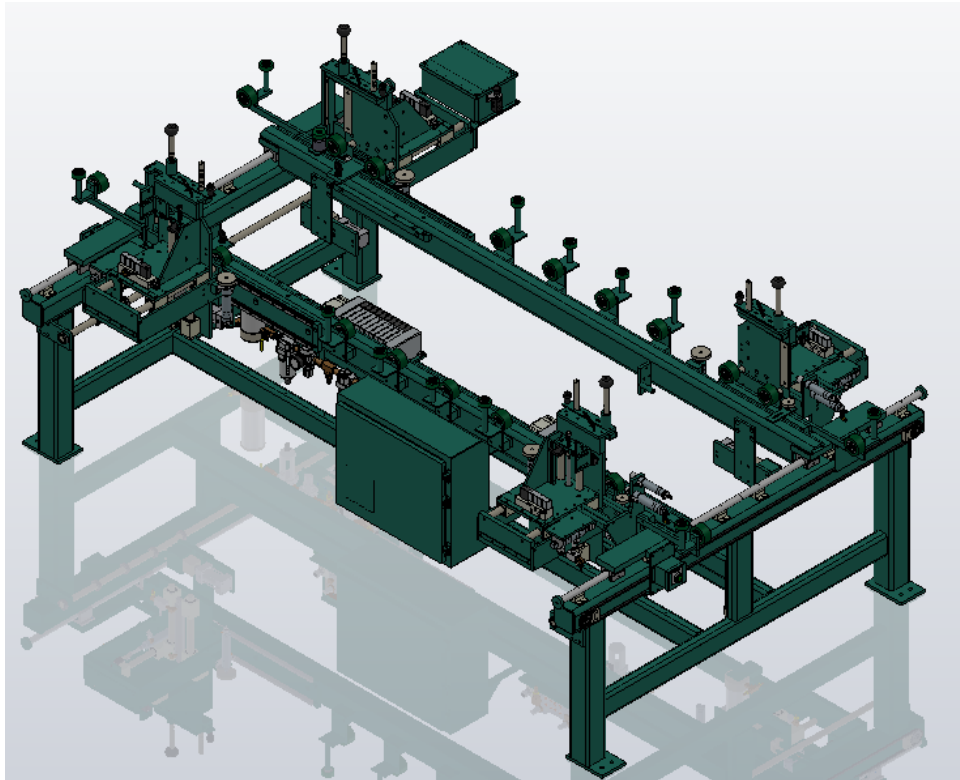

KVAL INC.
Instruction Manual



700-DC

Frame Assembly Machine

KVAL INC.

Operator's and Parts Manual

For further information about this manual or other Kval Incorporated products, contact the Customer Support Department, Kval Incorporated, 825 Petaluma Boulevard South, Petaluma, CA 94952. In the U.S and Canada, call (800) 553-5825 or fax (707) 762-0485. Outside the U.S. and Canada, call (707) 762-7367.

Kval Incorporated welcomes your opinion regarding this document. Please send them to the Customer Support address shown above.

Copyright © 2015 Kval Incorporated. All rights reserved.

All other products are trademarks or registered trademarks of their respective holders, all rights reserved. Reference to these products is not intended to imply affiliation with or sponsorship of Kval Incorporated.

Proprietary Notice

This document contains confidential and trade secret information, which is proprietary to Kval, Inc. ("Kval"), and is protected by laws pertaining to such materials. This document, the information in this document, and all rights there to are the sole and exclusive property of Kval, are intended for use by customers and employees of Kval, and are not to be copied, used, or disclosed to anyone, in whole or in part, without the express written permission of Kval. For authorization to copy this information, please call Kval Customer Support at

Copyright © 2015 Kval Incorporated. All rights reserved.

**825 Petaluma Blvd So.
Phone (707)-762-7367 • Fax (707)-762-0485**

www.kvalinc.com

Congratulations on your purchase of a new KVAL

700-DC

SERIAL No. _____

DATE OF PURCHASED _____

This manual is designed with safety in mind. We at KVAL want to begin FAST and SAFE production as soon as possible. It is very important that all OPERATORS and MAINTENANCE personal read this manual thoroughly. We have included important safety information that will help prevent serious injury; as well as complete maintenance, and troubleshooting instructions.

Proper operation and maintenance of your new KVAL machine will guarantee many years of trouble-free, fast-paced production.

Table of Contents

OPERATOR'S AND PARTS MANUAL.....	I
CUSTOMER SERVICE INFORMATION.....	1
PROPRIETARY NOTICE.....	1
CONTACTING KVAL.....	1
PRODUCT RETURN PROCEDURE	3
GETTING STARTED	4
SAFETY FIRST!.....	5
SAFETY RESPONSIBILITY.....	6
PROCEDURE TO LOCK OUT TAG OUT	6
TAG TYPES.....	7
ZERO ENERGY START UP	8
START-UP.....	8
INSPECT.....	8
CLEAN UP	8
REPLACE GUARDS.....	8
CHECK CONTROLS	8
REMOVE LOCKS	8
VISUAL CHECKS.....	8
SAFETY GUIDELINES.....	11
ELECTRICAL	11
COMPRESSED AIR:.....	11
OPERATING SAFETY:	11
COMPLIANCE WITH CODES AND REGULATIONS:.....	11
OPERATORS TRAINING:	11
OTHER HAZARD CONTROL ACTION:	11
700-DC GUARD PLACEMENT AND PURPOSE.....	12
UNPACKING THE KVAL 700-DC ASSEMBLY TABLE	15
PROPER LIFTING TECHNIQUES.....	16
ANCHORING THE MACHINE TO THE FLOOR	17
SPECIFICATIONS.....	17
AVAILABLE OPTIONS	19
TOUR OF THE MACHINE	20
TOP VIEW.....	20
OPERATING THE 700-DC.....	22
OPERATING THE STAPLE GUNS:	ERROR! BOOKMARK NOT DEFINED.
OPERATING THE STAPLE GUNS:	ERROR! BOOKMARK NOT DEFINED.

MAINTENANCE SCHEDULE	28
LUBRICATION SCHEDULE	29
PRIMING THE LUBRICATOR:	30
LUBRICATION REQUIREMENTS.....	30
LINEAR BEARINGS:	30
FLANGE BEARING:	30
LUBRICATE SPECIAL HIGH SPEED BEARINGS:	31
APPROVED LUBRICATION PRODUCTS:	31
LUBRICATOR ADJUSTMENTS:	31
GEAR MOTOR LUBRICATION REQUIREMENTS:	31
MIST OIL LUBRICATION:	31
BALL SCREW LUBRICATION:	31
LIMIT SWITCHES	32
GENERAL AIR CIRCUITRY TROUBLE SHOOTING:	32
BASIC ELECTRICAL TROUBLE SHOOTING:	34
<i>IF THE POWER STOPS DURING NORMAL OPERATIONS:</i>	<i>35</i>
ASSEMBLIES VIEWS	38
BILL OF MATERIALS	44

Customer Service Information

KVAL is happy to help its customer make the most of their investment, and help solve any problems that may occur. When you call, please have the electrical print, air print number, and the serial number of the machine ready, so that we are able to accommodate your needs efficiently.



Proprietary Notice

This Manual is confidential and contains proprietary information and intellectual property of KVAL Inc., and is to be used solely by Customer as an operating manual for KVAL Inc. machines. Neither this Manual nor any of the information contained herein may be reproduced or disclosed under any circumstances without the express written permission of KVAL Inc. For authorization to copy this information, please call Kval Customer Support at (800) 553-5825 or fax (707) 762-0485. Outside the U.S. and Canada, call (707) 762-7367.

The 979-2 Miter Trim Saw System is a trademark of Kval Incorporated.

Copyright 2015 Kval Incorporated. All rights reserved.

All other products are trademarks or registered trademarks of their respective holders, all rights reserved. Reference to these products is not intended to imply affiliation with or sponsorship of Kval Incorporated.

Contacting KVAL

Customer Service: For further information about this manual or other Kval Incorporated products, contact the Customer Support Department

- Mailing address:
Customer Support Department
Kval Incorporated
825 Petaluma Boulevard South
Petaluma, CA 94952
- Phone and Fax:
In the U.S and Canada, call (800) 553-5825 or fax (707) 762-0485
Outside the U.S. and Canada, call (707) 762-7367 or fax (707) 762-0485
- Business hours:
Technical Support:
6:00 AM to 4:00 PM Pacific Standard Time, Monday through Thursday
6:30 AM to 1:30 PM Pacific Standard Time, Friday
Parts & Service Sales:
6:30 AM to 4:00 PM Pacific Standard Time, Monday through Thursday
6:30 AM to 1:30 PM Pacific Standard Time, Friday
(Other sales related inquiries: <http://www.kvalinc.com>)
- Email: service@kvalinc.com

Your Feedback is Welcome: To help us design products that make your job easier and your business more successful, we'd like to gain your perspective about your user experience with our product - that is, the manual, the machinery, the software, etc. What was easy or difficult to use or to learn? If you could change something about the design, what would it be? Please email your comments and suggestions for improvement to userexperience@kvalinc.com. (**NOTE:** This is not a customer support email link. For that, please refer to the Customer Service contact information above.) Thank you!

Product Return Procedure

If you've contacted Kval for help and it is determined that a return is necessary, use the procedure below to return the machine or part.

Note: Non-Warranty returns are subject to a 15% restocking charge.

1. Obtain the packing slip and/or invoice numbers of the defective unit, and secure a purchase order number to cover repair costs in the event the unit is determined to be out of warranty.
2. Reason for return: Before you return the unit, have someone from your organization with a technical understanding of the machine and its application include answers to the following questions:
 - a. What is the extent of the failure/reason for return? What are the relevant error messages or error codes?
 - b. How long did it operate?
 - c. Did any other items fail at the same time?
 - d. What was happening when the unit failed (e.g., installing the unit, cycling power, starting other equipment, etc.)?
 - e. How was the product configured (in detail)?
 - f. Which, if any, cables were modified and how?
 - g. With what equipment is the unit interfaced?
 - h. What was the application?
 - i. What was the system environment (temperature, spacing, contaminants, etc.)?
3. Call Kval customer support for a Return Material Authorization (RMA). When you call:
 - Have the packing slip or invoice numbers available.
 - Have the documented reason for return available.
 - a. Send the merchandise back to Kval.
 - Make sure the item(s) you are returning are securely packaged and well protected from shipping damage
 - Include the packing slip or invoice numbers.
 - Include the documented reason for return.
 - Include the RMA number with the parts package.

Getting Started

Your new KVAL Machine arrives at your plant crated, banded, taped and has painted set collars on all shafts; keeping all of the precision moving parts secure during shipping.

1. Move the machine as close to the area it will be stationed before removing the crate to protect against damaging the machine with the forklift.
2. Remove the machine from the crate. Be careful! Anytime the machine is lifted to remove the skids there is a chance of the machine dropping suddenly, and damaging the machine, or injuring people near the machine.
3. Remove all painted set collars from the shafts. Just about every shaft on the machine has set collars to secure the moveable assembly mounted to the shafts.
4. Take off any tape securing the various buttons, switches and knobs.
5. Level your KVAL machine by putting metal shims underneath the corners of the base. Leave a clear shot from the bolt holes in the foot pads to your shop floor. Now, make sure the machine won't rock back and forth.
6. Once the machine is level, anchor it to the floor so that it won't move across the floor during operation. KVAL recommends a ½ RED HEAD, TRUE BOLT ANCHOR in each of the foot pads. When drilling the concrete for the anchor bolts use a 5/8 bit.

Note:

KVAL wants to provide the industry's safest and highest quality wood working machines. The following page is a quality control and safety checklist. Our technicians have already performed an initial quality control check before shipping your machine. Please review the checklist and return "Acknowledgment Copy" to KVAL Verifying

Safety First!

This section contains important safety information. Failure to follow these safety guidelines may subject the operator to physical hazards that may result in serious bodily harm, or death.



Safety Responsibility

It is the responsibility of each employee to maintain safe working conditions in his or her area. Failure to understand and correctly follow this procedure is direct violation of safety rules and regulations. Violations of this policy can lead to severe injury.

Procedure to Lock Out Tag Out

To lockout or tag out a piece of equipment, the following steps must be taken:

1. Assess the equipment to fully understand all energy sources (multiple electrical supplies air and/or hydraulic pressures, spring tension, weight shifts, etc.)
2. Inform all affected personnel of the eminent shutdown, and the duration of the shutdown.
3. Obtain lock and tags from employer.
4. Shutdown machine(s) by normal means, i.e., disconnect switch (es), air pressure relief valve (es), on/off button, etc. NOTE: Control power switches do not serve as adequate shutdown devices. The main source(s) of energy must be disconnected as well. Also, ensure that all mechanically stored energy has been released, i.e., lifting booms lowered to bottom of travel, carriages in "HOME" position etc., No one may remove a tag or lock installed by someone else. Only the person who attached the tag or lock is authorized to remove it.
5. Once the lock and tag is in place, the employee must try to operate the machine to ensure all energy sources are defeated.
6. When maintenance or repairs are completed, the person that did the work must ensure all tools, spare parts, test equipment, etc. are completely removed and that all guards and safety devices are installed.
7. Before removing the lock and tag, the person who attached them shall inspect the equipment to ensure that the machine will not be put in an unsafe condition when re-energized.
8. The lock and tag can now be removed (only by the person who place them), and the machine can be re-energized.
9. The tag shall be destroyed and the lock and key returned to the lockout center.

In addition to safety concerns, this policy is required by OSHA regulation 1910.147 and Cal OSHA'S SB198 ruling of July 1991.

Tag Types



ZERO ENERGY START UP

Zero Energy State to Start-up to Operating State

Starting the equipment is just as important as Lock-Out/Tag-Out in terms of safety.

Start-up

- Inspection
- Clean up
- Replace guards
- Check controls
- Remove locks
- Visual checks

Inspect

When work is finished the equipment must be inspected for proper adjustment before starting equipment.

Clean Up

All materials and debris must be cleaned up. Any combustible materials and old parts used during repairs must be cleaned up.

Replace Guards

Replace all guards to the equipment. If adjustments can not be made with the guard on after start-up, leave off only the ones to be adjusted after start-up.

Check Controls

Make sure all switches are in the off position. In some cases the machine can start automatically when energy is restored.

Remove Locks

Each person must remove his or her own lock or tag. This will ensure you are in a safe place when the equipment is started.

Visual Checks

If the equipment is too large to see all around it, station personnel around the area and sound the personnel alarm before starting the equipment. If your operation is more complex, having many pieces of equipment and a lot of people, a comprehensive Lock-Out/Tag-Out procedure may involve additional steps. You will need to ask your supervisor about these procedures. A specific lock out procedure may be posted at each machine. On larger or long term maintenance projects or installation projects, the procedures should be explained to all participants and a copy of the procedures posted on site for the duration of the work. Provisions which ensure protection during shift changes when contractor or outside help is used also need to follow the Lock-Out/Tag-Out Procedures. Comprehensive Lock-Out/Tag-

Out may use a gang box or other system to ensure that locks are secure and not removed without authorization.

Remember Lock-Out Tag-Out procedures work because you are the only one with the key to your lock. Proper Lock-Out/Tag-Out can save lives, limbs and money. Help make your work environment safe for yourself and your fellow employees. Make sure you follow the P-R-OP-E-R Lock-Out/Tag-Out procedures, and that those around you do also.

YOUR LIFE MAY DEPEND ON IT.

<http://www.concrete-pipe.org/sab.htm>

© 2004 American Concrete Pipe Association (ACPA). All Rights Reserved.

Lock Out Diagrams

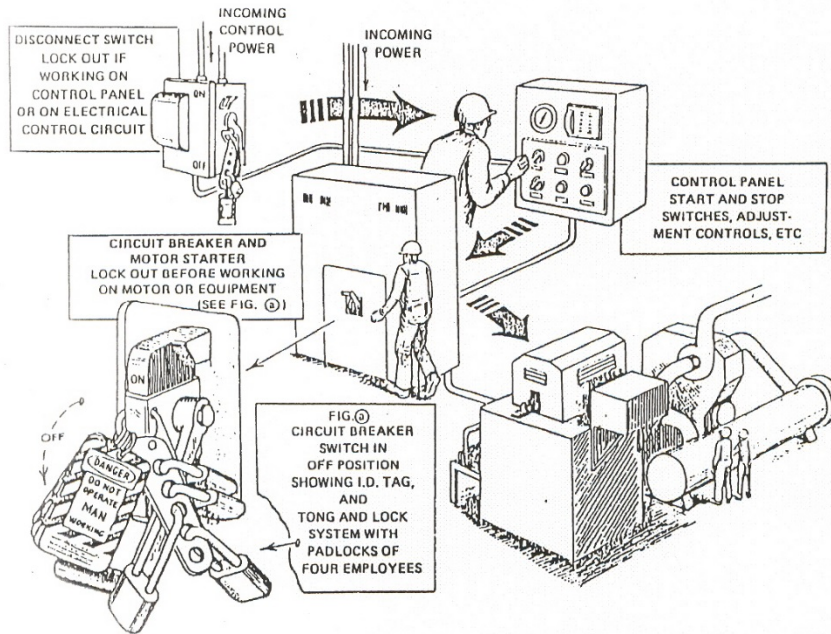

Illustration 1
Lockout/Tagout Procedure for Electrical Energy Source

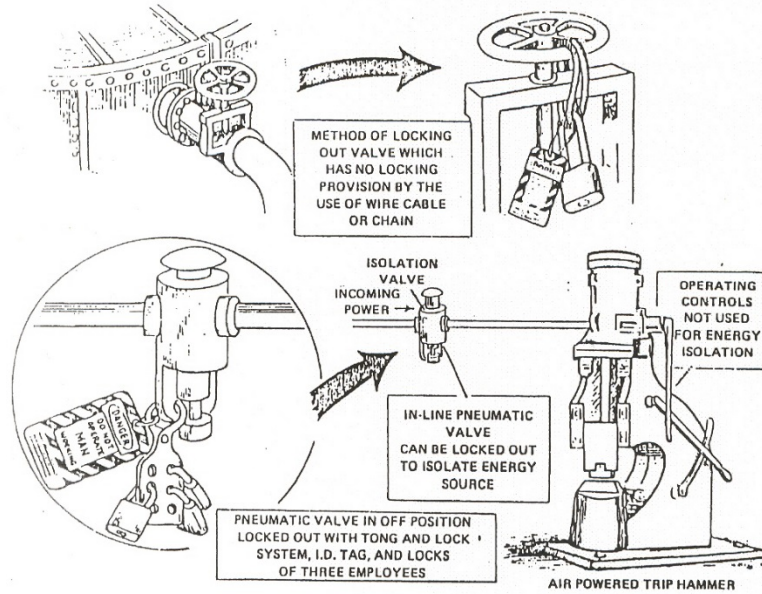

Illustration 2
Lockout/Tagout Procedure for Hydraulic-Pneumatic Energy Source

Safety Guidelines

Electrical

Electrical circuitry on this machine is protected by an approved lockable disconnect circuit. In addition to this equipment, you must install an approved disconnect for the electrical power supplying this machine

Compressed Air:

The compressed air system connected to this machine should have a three-way air valve for shut-off and pressure relief. The air supply providing the pressure to this machine also has a three-way air valve for the supply line.

Operating Safety:

Prior to changing any cutters or doing any maintenance work, you must disconnect, tag out, or lock out the electrical, air pressure and hydraulic systems. This should be done in accordance with the State and/or Federal code requirements.

Compliance with Codes and Regulations:

It is advised that you request an on-site State safety review of your installation of this machine. This is to ensure conformance to any additional specific safety and health regulations which apply in your area.

Operators Training:

You must ensure that all operators of this machine be trained to know the potential electrical hazards, pressure pinch points, rotating cutters, and other similar hazards. It is also your responsibility to train the operators, or potential operators on how to operate the machine safely.

Other Hazard Control Action:

If you believe that any part or operation of this machine is in violation of any health or safety regulation, it is your responsibility to immediately protect your employees against any such hazard and bring the matter to our attention for review and correction, if deemed advisable.

You will not that additional detailed safety guidelines are included in the operating instructions of this manual. We will be pleased to review with you any questions you may have regarding the safe operations of this machine.

700-DC Guard Placement and Purpose

The in feed /out feed wheel guard's location is over both wheel assemblies. These guards protect the operator from getting any body parts pinched by the wheel assembly and the frame. Possible injuries from getting any part of the body caught by the wheel assembly may include:

- Broken Bones
- Bruises
- Cuts and Amputation

Never operate the 700 without the guards.

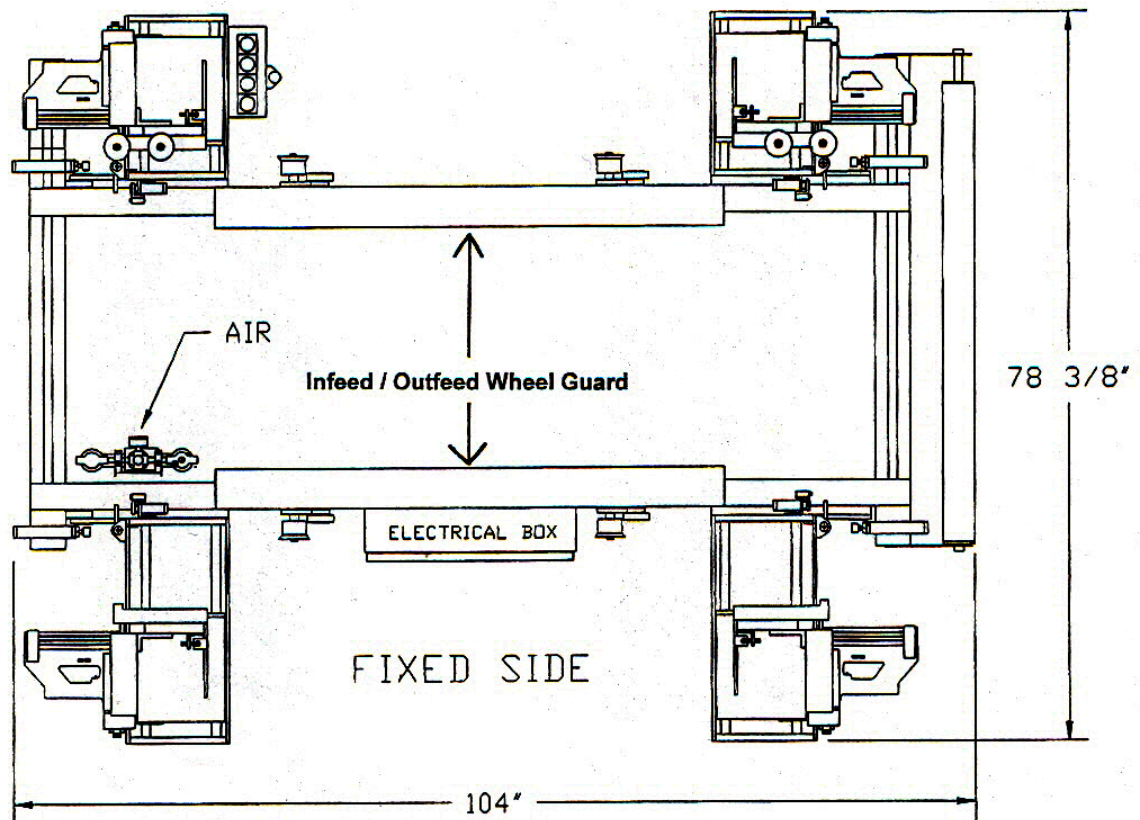

Unpacking the KVAL 700-DC Assembly Table

The Kval 700-DC assembles leg jambs to a head jamb to create a door frame. It has no other intended use. The lock side jamb and a header a jamb are inserted by the operator, next a door and attached hinge jamb are rolled into the bed of the machine. The header jamb is positioned either in the left or right end clamping fixtures which determines door swing orientation.

The machine provides several fixtures and air clamps to significantly aid the operator in correct alignment and clamping of the door and jamb components. Once aligned and clamped, fixtured staple guns are activated by a push button to automatically position and fire staples through the leg jambs into the head jamb. Finally, the unit is elevated on rollers for ease of off-loading.

Weight of the equipment:

Shipping weight is 1700 lbs. or approximately 772 kilograms

Removing Packaging & Positioning:

The 700-DC arrives on a heavy timber platform. Major assemblies are banded in position, various components are taped in place, and painted set collars are locked on shaft slides to keep precision moving parts secure during shipping'.

To remove the timber platform first remove lag bolts securing the frame to wood. Then lift the machine with two forklifts as shown in the accompanying photos, then slide the platform out. **BE CAREFUL!** Anytime the machine is lifted there is a chance of the machine dropping suddenly, and damaging the machine or injuring people near the machine.

Remove banding materials and tape.

Residual Risks:

The electrical and compressed air services to this machine must be locked out and tagged out prior to performing any maintenance activity. Risk of serious injury exists if this not done. It is the responsibility of management and employees to implement and follow this policy.

More detailed information on safe working policies and practices are described under Safety Guidelines section of this manual, and it contains a page detailing lock! tag out procedures. It's vital that these sections are understood and followed to prevent injury!

With both air and electrical services locked and tagged out, and mechanisms at rest, there are no residual mechanical movements or electrical risks that Kval can foresee. Of course common sense and general mechanical and electrical training is required when working around any electro/mechanical device. If questions ever arise, please contact Kval for assistance.

Proper Lifting Techniques

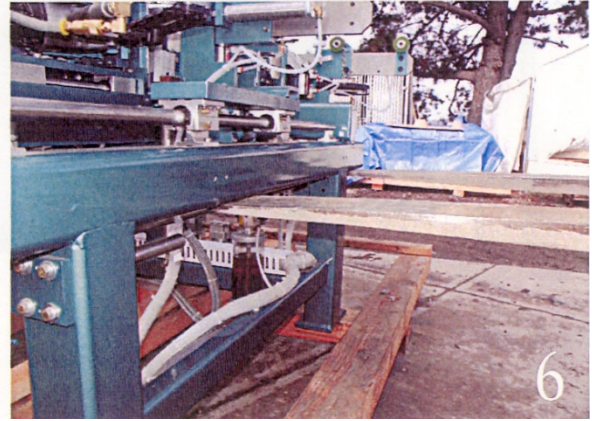
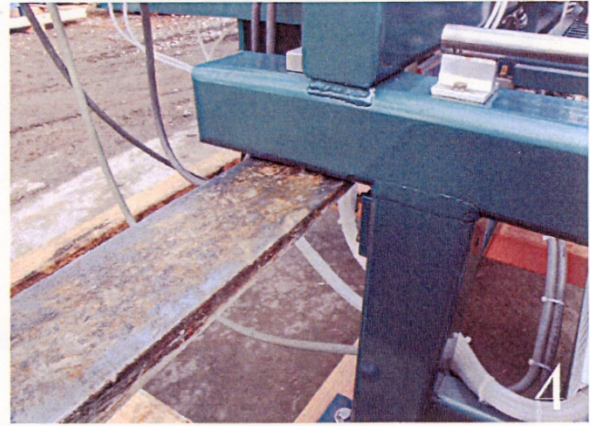
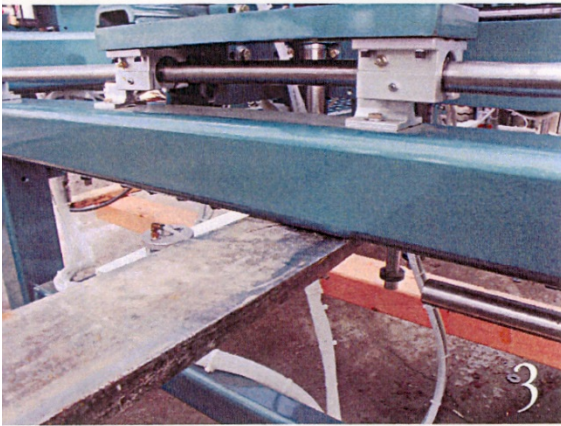
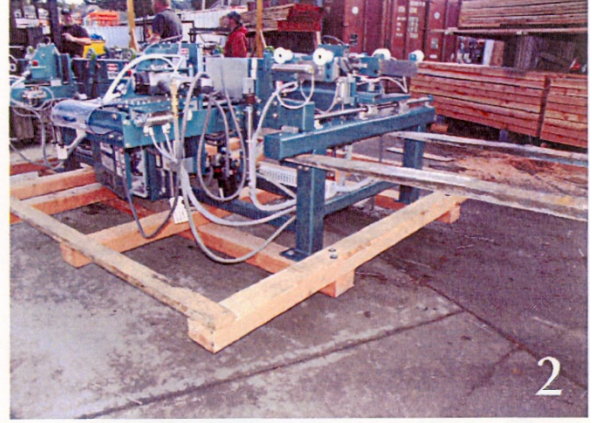
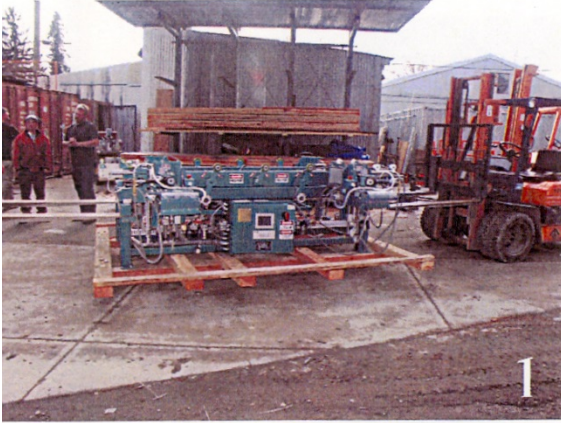

Anchoring the Machine to the Floor

When the machine has been set-up and a test run has been done to ensure that it is feeding the material properly. Kval recommends anchoring the machine to the floor with 1/2" Red Head, True Bolt Anchors in each of the foot pads. An Alternative to bolting the machine, you may want to use Epoxy and hardened threaded rods to prevent the bolts from vibrating loose. Kval doesn't require the use of epoxy though its added fastening strength is significant

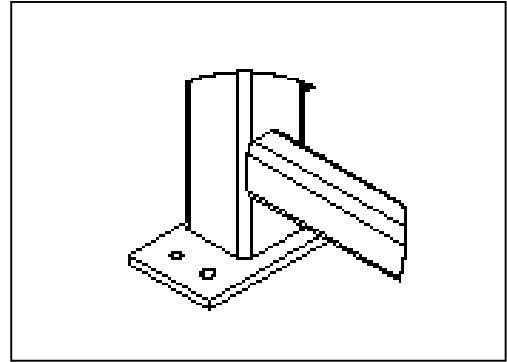

STANDARD ANCHORING INSTRUCTIONS

- With machine in place and leveled, drill 3" deep holes in the concrete using a 5/8" diameter masonry bit., using the mounting holes as guides.
- Clean out holes with a blowout-bulb or air compressor to ensure that the anchor heads get a firm bite on the walls of the holes
- Insert anchors through the mounting holes in the foot pads and into the holes you have drilled into the concrete. If an anchor's expansion sleeve binds inside the hole, simply tap the bolt head with a hammer until bolt head is flush with the surface of the foot pad

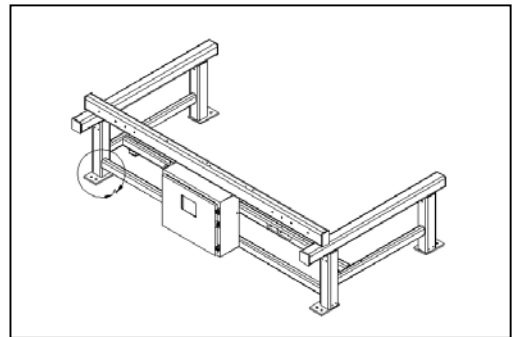

ANCHORING USING EPOXY

- With machine in place and leveled, drill 3" deep holes in the concrete using a 9/16" diameter masonry bit, using the mounting holes as guides.
- Clean holes with blowout-bulb or air compressor. Complete hole preparation with use of a nylon brush, NOT A WIRE BRUSH
- When starting a fresh cartridge of anchoring epoxy, epoxy must be an evenly blended light gray color. Insert the nozzle into the bottom of the hole. Fill hole 1/2 the hole depth.
- Inset 1/2", (hardened) threaded rod into the bottom of the hole using a slow twisting motion. This insures the epoxy fills voids and crevices. Hardening begins in 7 minutes @ room temperature.
- After recommended cure time, bolt in place

Specifications

The KVAL 700-DC Frame Assembly Machine has pop-up door supports that accommodate any door sill that does not extend past the interior side of the door frame. The machine is equipped with an electronic PLC programmable logic controller so all operations are performed by pressing the same foot pedal.

First a door, with hinge jamb and sweep attached, is rolled into position on hold-up wheels. The foot pedal is pressed once to close the hinge side and hold it in position. The pedal is

pressed a second time to clamp and hold in place the head, strike jamb and sill.

After the frame is clamped, the operator pushes a single button to simultaneously secure all four of the corners. Another button unclamps the door and releases it so it can be rolled to the next station.

For sills that are attached with screws, the 700-DC can be purchased with just two staple guns for the header. The sill end then functions as a clamp to compress the sweep and ensure tight alignment.

A hand-held air screwdriver is used to fasten the sill as the head is attached with staples. The price does not include staple guns or air screwdrivers.

SPECIFICATIONS

Footprint Size: 6'x 10'

Crated Dimensions: 120"L x 80"W x 53"H

Shipping Weight: 1,200 lbs.

Staple guns suitable for mounting on this machine include:	
Bostich	750S5-1 (7/16" Crown) and 750S4-1 (1/2" Crown)
Duo Fast	KS 7648 or MS 7664
Paslode	PA 200 S-16
Paslode	MA-080-T (T-Nailer)
Power Line	AOL
Senco	K or M-11
Spot Nail	HL7216

Available Options

Option	Description
Option B: Auto Screw driving System for Attaching Sill	Automatic screw driving assemblies with integral pilot hole drills will be mounted on each side of the sill end of the 700-DC for attaching the sill. Two screws is installed on each side. Price includes automatic screw feed system, controls, and integration into the control panel of the 700-DC.
Option D: 6'8",7'0" & 8'0" Door Length Capability	Options consists of extension arms for support wheels and end clamps. Option includes two sets of infeed gravity stops.
Option D1: 6'6" to 8'0" Moving Head End	Head end clamp assemblies with staple guns is mounted on linear bearing shafts. Each head end clamp assembly will have stops for 6'6", 6'8", 7'0" & 8'0" door units. The clamp assemblies is held in position with pins that can be quickly removed without the aid of tools.
Option D2: 6'6" Door Capability	6'6" Door Capability
Option: Tooling and Lubricant Package	Please review with your KVAL consultant to determine your needs.
Option: Spare Parts Package	Please review with your KVAL consultant to determine your needs.
Option: UL	Electric panel is built according to Underwriter's Laboratories specifications, and 'UL' Label applied.
Option: Canada Service Contract Subscription	At the time of machinery purchase, Canadian clients are required to purchase a Machinery Service Contract Subscription that is to be renewed annually. Without this annual subscription, as directed by the Canadian government, no services (including installation or warranty work) can be performed by KVAL technicians in the customer's plant.

Tour of the Machine

Top View

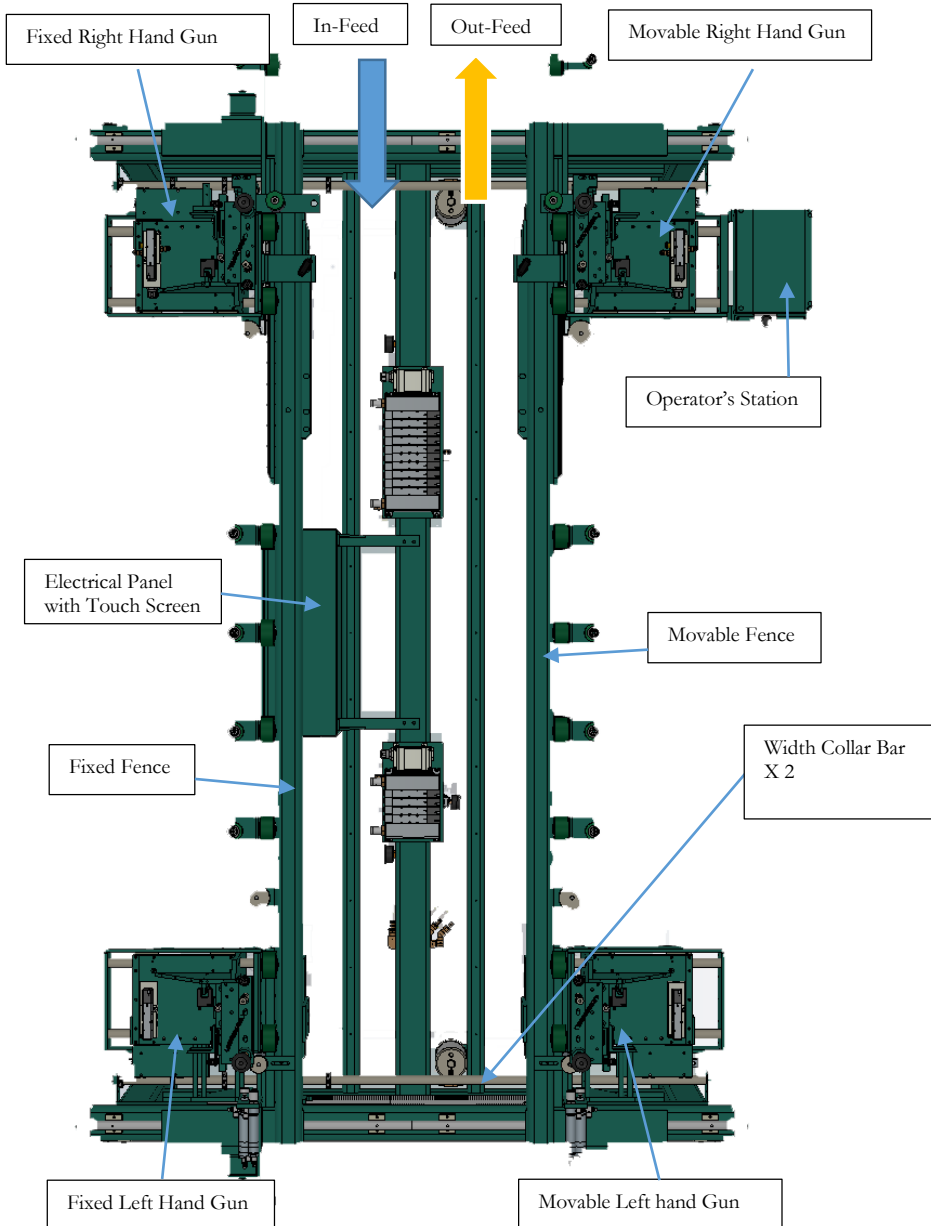

Operator Side View

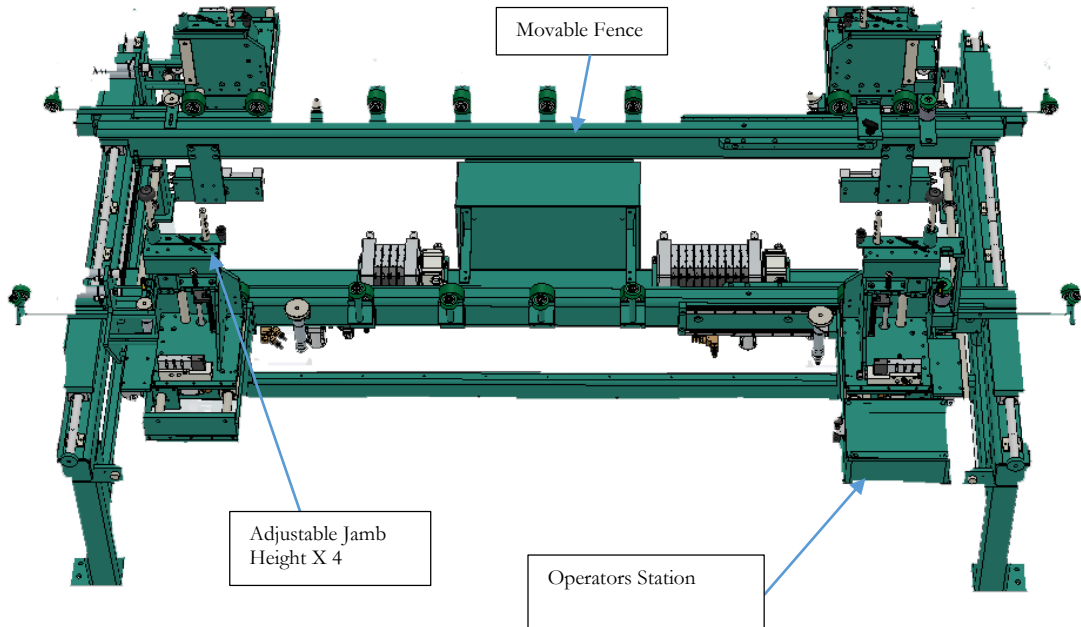

Electrical Panel View Side

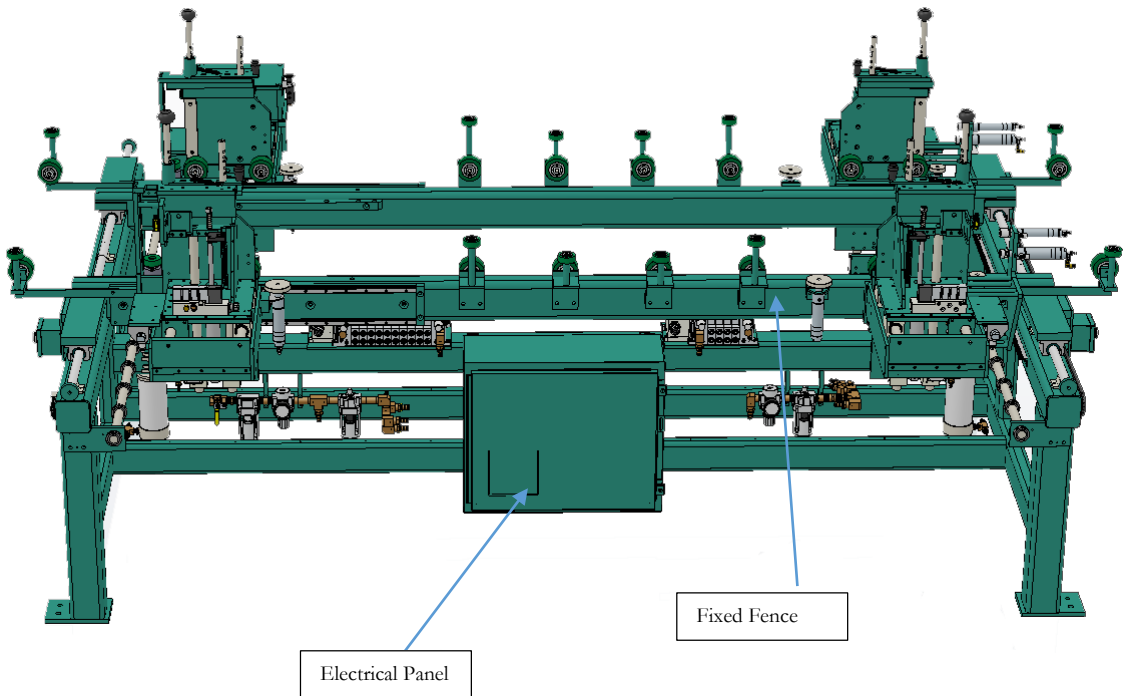

Operating the 700-DC

1. Power up the 700-DC.
2. Select the Jamb type.
3. Select Door length (Optional).
4. Select a jamb width.
5. Select a staple sequence.
6. Insure the proper staple guns are enabled and staples are loaded.
7. Adjust the machine for the desired door width.
8. Insert the jambs

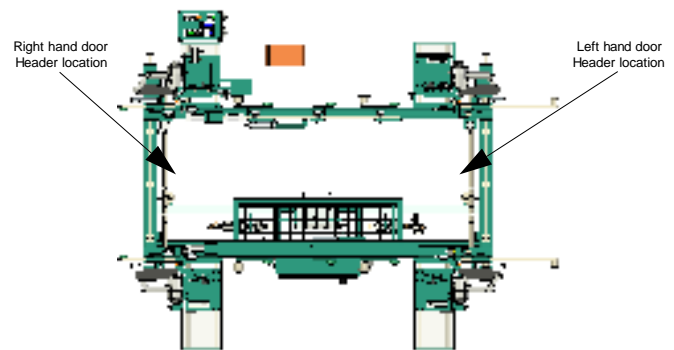

9. Insert Strike Jamb and insure head and strike jamb corners meet.
10. Make sure the vertical adjusters are set on the jambs
11. Pull in the door, verify header is clear so heads can come in. Have a little wiggle room.



Make Sure Heads Clear
Have a little wiggle room
with door and jabs

Make Sure Jambs are secure
with vertical adjust on all 4
heads

12. Push the Sequence Forward foot switch (brings in movable side staplers).
13. Push the sequence Forward foot switch (drops door to lower position).

14. Insure the hinge jamb is in the correct position in relation to the head jamb.
15. Set Sill in place



16. Push the sequence foot switch (brings in the fixed side staple guns).
17. Push the sequence forward foot switch (clamps the door).



18. Press Fire Guns
19. Push the Sequence Forward foot switch (un-clamps door).
20. Pull out the Door



21. Press Reset. (Returns machine to start position).

Turning the 700-DC On and Off

Use the procedures below for powering up and powering down the 700-DC.

Powering Up the 700-DC

1. Make sure the electrical disconnect the electrical cabinet is turned to the ON position.
2. Turn the CONTROL TRANSFORMER switch located on the main control panel to the ON position.

Powering Down the 700-DC

1. Turn the CONTROL TRANSFORMER switch to the OFF position. This kills power to the machine.
2. KVAL recommends turning off the Power Disconnect. This kills power to the machine. Reduce possible damage resulting from power surges from electrical storms.

Main Control

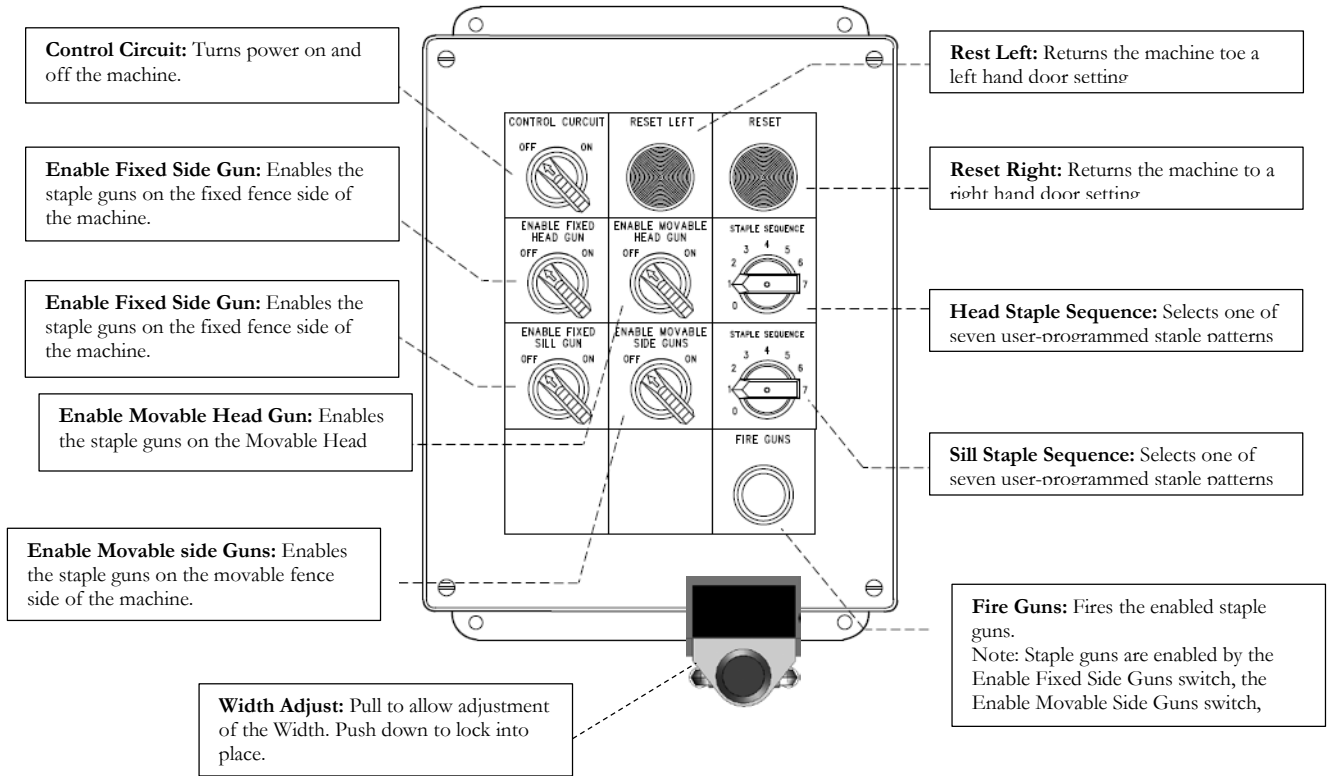

Length Adjust

Adjust the length by pulling up the T Handle Pin adjust and move the Head to desired length. Lock by Securing the T Handle in the appropriate adjustment hole. See next figures for an example of length adjustments. (6'.6", 6'.8", 7'.0" and 8'.0")

Head Set for 8'.0" Length

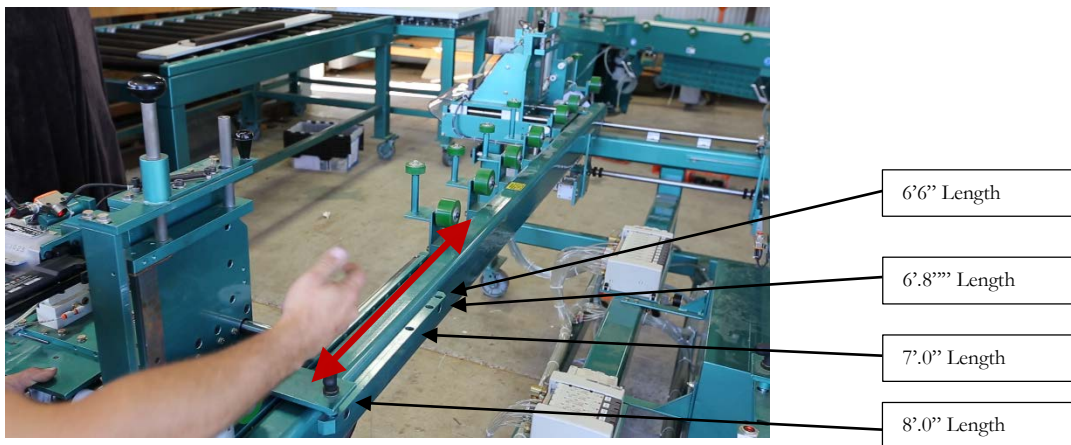

Head Set for 6'.6" Length

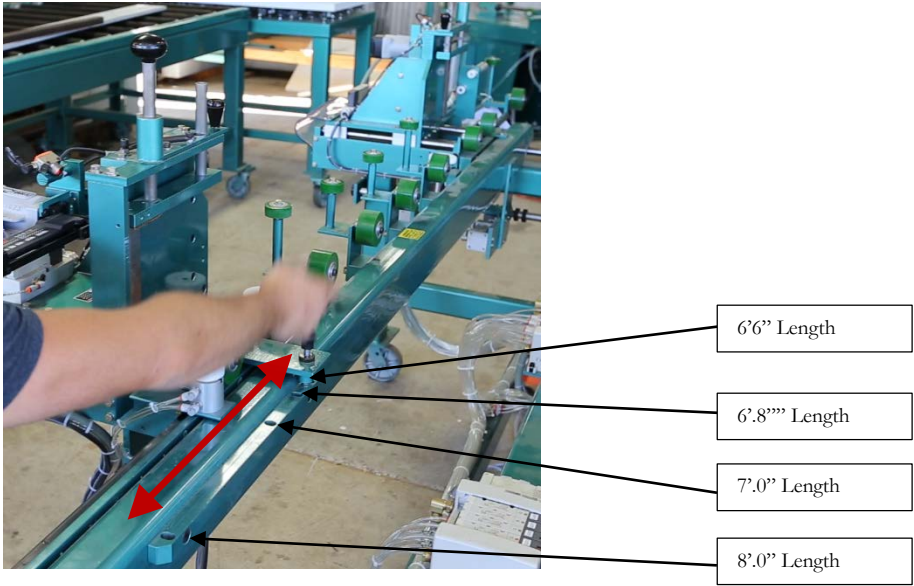

Width Adjust

The following describes adjusting the 700-DC to accommodate different door widths. The picture below shows the location of the width adjust system components.

1. Pull up the width adjust button located on the main control panel or the (optional) remote control panel. This will retract the pickle forks freeing the movable fence for positioning.
2. Slide the movable fence until Pickle Fork is at the desired location on the **Collar Bar**. Both fences move. The Pickle Forks have a 1.0" width equaling to 1.0" per side for a total of 2.0" change in width.
3. After width is set, push the width adjust button down to extent the Pickle Fork.

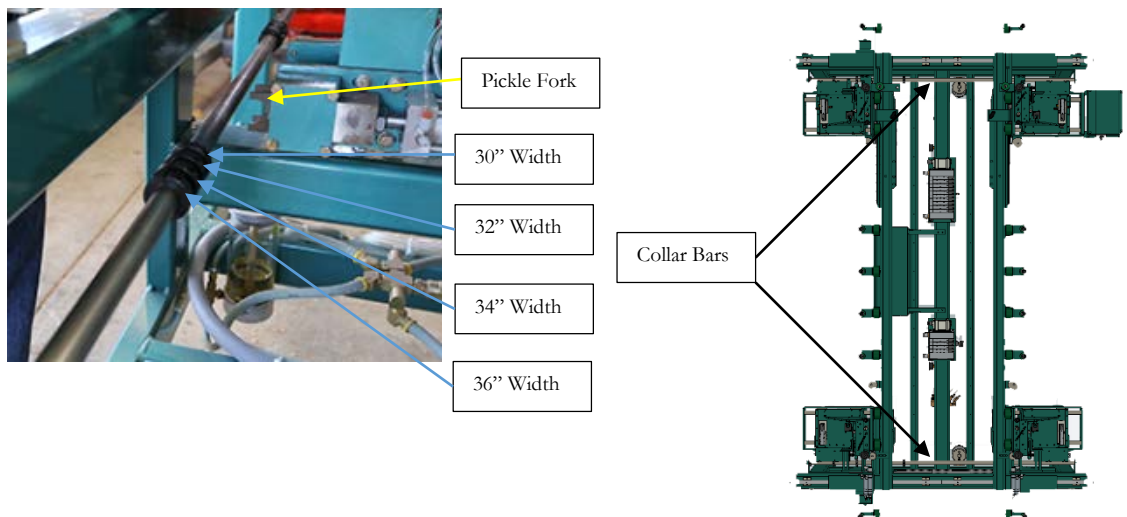

Touch Screen Interface

The following is an overview of the touchscreen functions for basic machine operation.

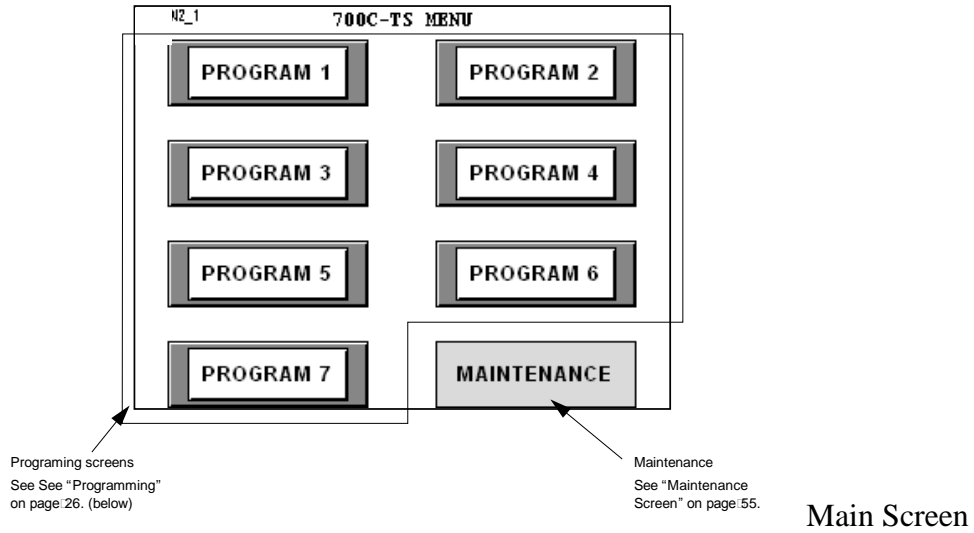

Programming

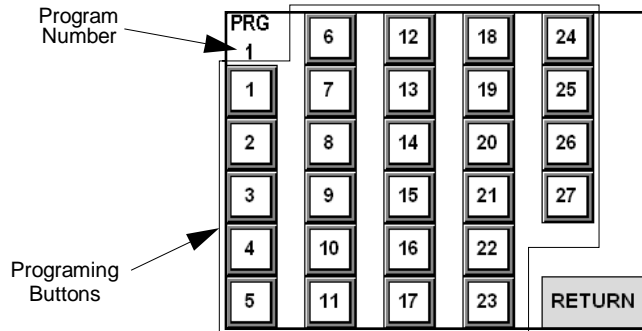

Programming Buttons

1	3/4"
2	1"
3	1 1/4"
4	1 1/2"
5	1 3/4"
6	2"
7	2 1/4"
8	2 1/2"
9	2 3/4"
10	3"
11	3 1/4"
12	3 1/2"
13	3 3/4"
14	4"
15	4 1/4"
16	4 1/2"
17	4 3/4"
18	5"
19	5 1/2"
20	5 1/2"
21	5 3/4"
22	6"
23	6 1/4"
24	6 1/2"
25	6 3/4"
26	7"
27	7 1/4"

The programming buttons determine where staples will be fired into the jamb. For all programs a staple is fired approximately 1/2" below the top of the jamb in reference to how the jamb is oriented in the 700-C. The programming buttons are used to toggle other staple locations.

For example:

If staples were desired at 1/2", 2" and 3 1/4", programming buttons 6 and 11 would be pushed.

* 1/2: A staple is always fired at this location.

* 2": This location requires button 6 pressed.

* 3 1/4": This location requires Button 11 pressed.

Note: All programming button locations have a tolerance of +/- 1/4"

Maintenance Schedule

Daily Preventive Maintenance	
Op	Operation Description
Clean	Blow off dust from the entire machine. Wipe down the outside of the machine with a clean dry cloth.
Check	Check tooling for wear.
Clean	Wipe off the photo eyes with a clean dry cloth, and check to ensure that all fastening nuts are snug.
Check	Check the air pressure to make sure it is set at 80 psi to 100 psi.
Clean	Empty any Dust Collection Units.
Check	Check for obstructed flow when excessive sawdust appears.
Check	Check the air filter water trap. Empty if full.
Weekly Preventive Maintenance	
Op	Operation Description
Check	Check the machine for smooth motion through a complete door cycle
Clean	Clean linear bearings and the chrome shaft with a clean dry cloth, then lubricate.
Check	Check all air lines & electrical wiring for kinks or rubbing.
LUBE	Refill lubricator with an ISO 32 standard hydraulic oil (KVAL part# SYSLUBG)
Six Month Preventive Maintenance	
Op	Operation Description
Clean	Wash filter and lubricator bowls with soapy water.
LUBE	Grease all bearings and tighten all bolts. Access to some grease fittings is difficult and will require a special needle point grease tip (supplied with your system).
Clean	Clean and lubricate all slides and cylinder rods with dry silicone spray.
Tighten	Tighten all bolts.
Back-up	Backup computer software.
LUBE	Lubricate linear bearings and chrome shafts with silicone.

Lubrication Schedule

KVAL recommends the following lubrication schedule to ensure that the machine operates properly.

Type of Assembly	Recommended Schedule	Recommended Lubrication Type
Linear Bearing	Every 250 Hours of Machine Operation	Dura-Lith Grease (KVAL P/N Lube EP-2)
Pillow Block Bearing		
Flange Block Bearing		
Ball Screw	Every 80 Hours of Machine Operation	
Air Line Lubricator	One drop of oil every 2 or 3 cycles Check the lines every week to two weeks	<ul style="list-style-type: none"> • Either lubricant listed below is approved to use. • KVAL P/N SYSLUBG • Chevron AW Hydraulic Oil 32 • G-C lubricants light AW R&O • Mobile DTE 24 • Shell Tellus32 • Gulf Harmony 32
Gear Box	2000 Hours of Machine Operation or six months of operation	<ul style="list-style-type: none"> • AGMA #8 gear lube • MOBILUBE HD 80 W-90 • or equivalent

Priming the Lubricator:

New and used machinery run out of oil from time to time. It is a good practice to check your machine lubricator to insure that it is putting the proper dose of oil in the air lines. Usually 1 drop every 3-4 cycles is a good rule of thumb.

To prime the lubricator, find an airline on the Front Section of the machine that is energized, and disconnect it, allowing the air stream to bleed air pressure away from any persons. Direct the air stream at the machine so you can see when there is an oily film blowing out of the air hose. NOTE: It might take up to 15 minutes to get a good prime. When this is accomplished, place the airline back into its original position.

Repeat this same procedure for the back section and other trouble areas.

Check the lines every week to two weeks

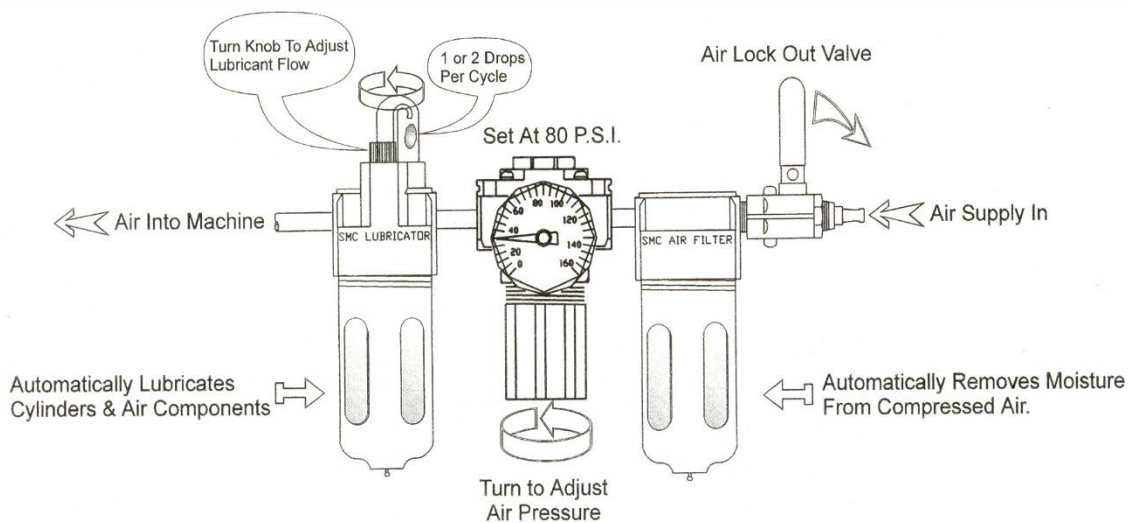

Lubrication requirements

Linear Bearings:

If bearing is equipped with a grease fitting, it should receive 1 Gram (one pump from grease gun) of Dura-Lith Grease (KVAL P/N Lube EP-2) grease every 30 days. Bearings without grease fittings have been pre-lubricated at the factory and do not require further lubrication.

Flange Bearing:

Dura-Lith grease; 1 gram every 60 days.

Lubricate special high speed bearings:

With optimal long time PD2 (KVAL P/N Lube PD2) bearings must be re-lubricated once every 60 days.

Approved Lubrication Products:

Chevron AW Hydraulic Oil 32 – or KVAL P/N SYSLUBG or G-C lubricants light AW R&O or Mobile DTE 24 or Shell Tellus32 or Gulf Harmony 32.

Lubricator Adjustments:

Using knob on the top of the lubricator, adjust until one drop per every other cycle is used (as observed through sight glass.) Turn flow all the way open then reduce flow to proper specifications.

Gear Motor Lubrication Requirements:

Oil change is recommended after 2000 hrs. or six months of operation. Use AGMA #8 gear lube or MOBILUBE HD 80 W-90 or equivalent.

Mist Oil Lubrication:

Spindle housing mist oilers require sys-lube lubricant, available through KVAL. Optimum flow is 3 to 5 drops per minute @ 5-10 psi.

Ball Screw Lubrication:

Standard lubrication practices as applied for antifriction bearings can be used for ball screw assemblies, too. Either oil or grease can be used as lubricant. Because the axial motion between screw and nut, however, lubricant loss is slightly greater than in conventional antifriction bearings. This means that in most cases the initial supply of grease will not last for the entire service life of the assembly.

GRAPHITE and MoS₂ additives must NOT be used.

Temperature is one of the major influences affecting the performance of ball screw assemblies. This is because thermal expansion will interfere with the positioning accuracy of the assembly. One of the advantages of oil lubrication is that it keeps heat-up of the ball screw assembly low, especially at medium and high speeds.

Limit Switches

If a machine suddenly stops in mid cycle check the limit switches, a worn limit switch arm or a misadjusted limit switch is more than likely the cause. Depending on the model of limit switch you receive the amount of “pre-travel” (amount of movement from the arms resting position) is either 5 or 20 degrees before the limit switch actuates (Clicks). If the arm is moved to the full extents of its travel and you do not here the limit switch “Click”, the switch needs to be adjusted here is how you adjust it follow the following drawings.

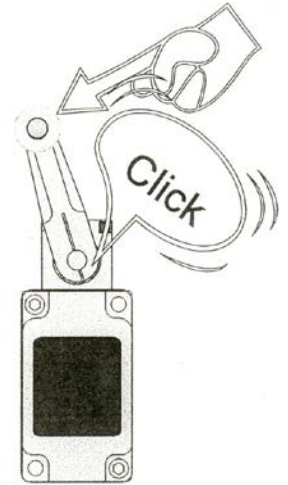
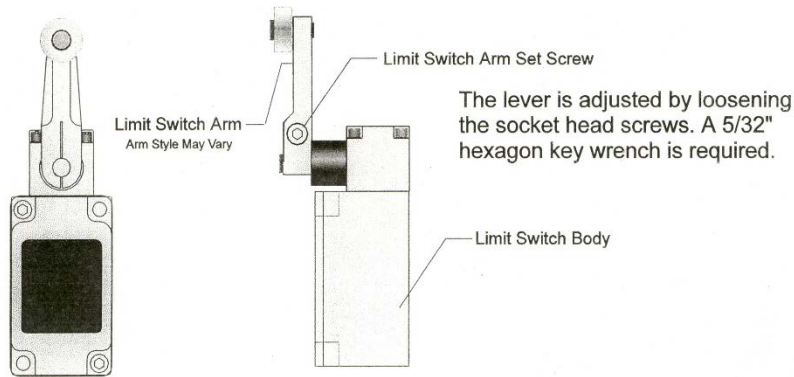

General Air Circuitry Trouble Shooting:

If a cylinder is not functioning correctly here are a couple of items to check:

1. Check the air pressure to the machine.
2. Check the flow controls to see that they are adjusted correctly and to the proper specifications.

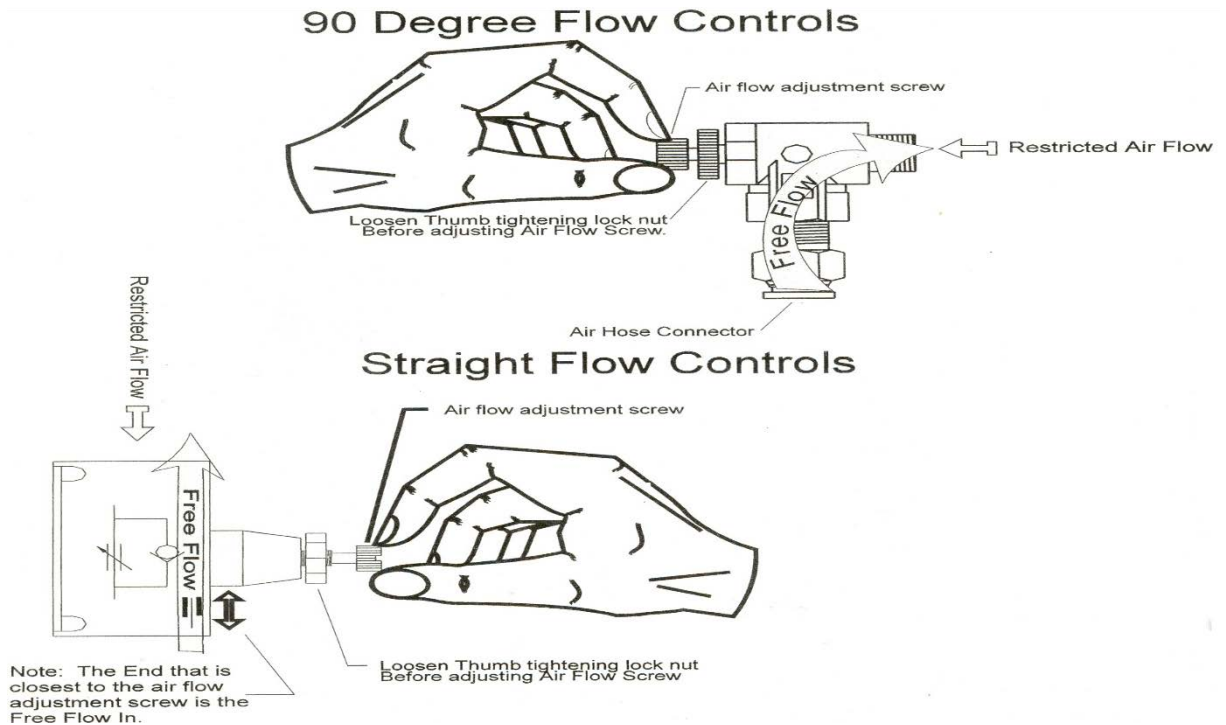

3. Check for and obstructions to the cylinders such as screws or a misplaced tool etc...
 * FOLLOW ALL SAFETY GUIDELINES AND SIGNS DURING THIS PROCESS.

Check the air valves:

The air valves can be manually operated by pushing the slotted button on the end of the valve. If you wish to keep the valve open, the push button assembly can be removed using an open ended wrench and inserting a 3/8" N.C. cap screw. DO NOT over tight when reassembling the valve.

If the valve seems to be leaking, the seals may be dry or contaminated with water or it maybe that the cylinder "O" rings are damaged and air is passing from one side to the other side of the cylinder. It maybe is necessary to purchase a rebuild kit or a new cylinder.

If the valve is not receiving an electrical signal, see "Electrical Trouble Shooting" instruction. It might be necessary to call in a specialist or check with KVAL customer service at 1-800-553-5825

If an Air Leak is coming from an exhaust port on the air bank:

Check the solenoid for the manual override. If the solenoid has a manual override you can push each of the buttons one at a time. When the air leak stops or weakens it usually means that one or more of the cylinders that the solenoid is operating are faulty.

Adjusting the flow controls to change the cylinder extension speed is done by the following drawing. Please review this drawing as this adjustment is not done in a normal manner.

To change cylinder extension speed:

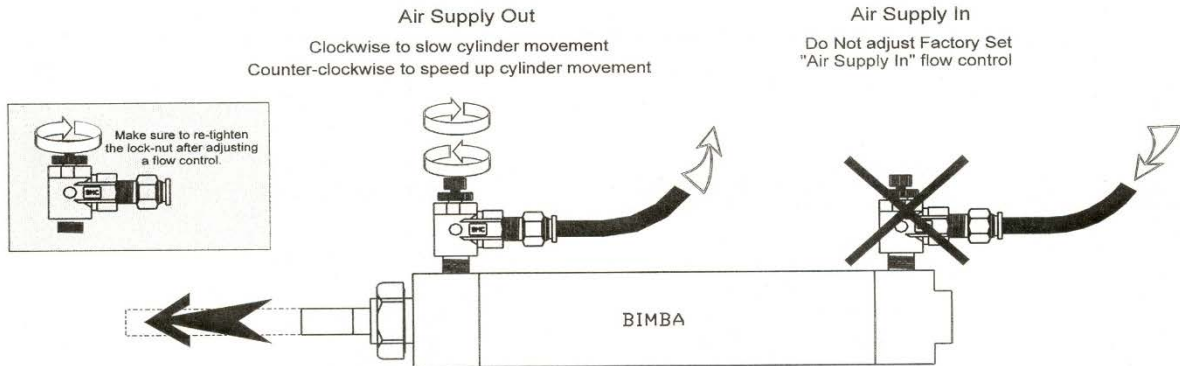

To change cylinder retraction speed:

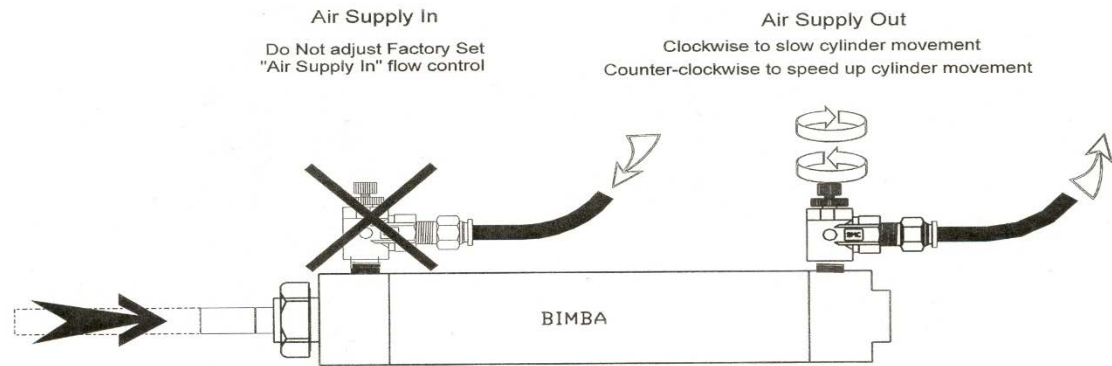

Basic Electrical Trouble Shooting:

THE FOLLOWING SHOULD ONLY BE ATTEMPTED BY TRAINED ELECTRICAL PERSONNEL.

The electrical component systems are designed to expedite the troubleshooting process and minimize "down time". In general, component systems have the input or feed functions at the top. Output or load functions are positioned at the bottom. Most two voltage electrical panels are designed with the **LOW VOLTAGES** on the **LEFT**, and the **HIGH VOLTAGES** on the **RIGHT**. The majority of the system components are labeled

with numbers that correspond with the electrical prints included in the electrical box door.

Computer controlled machines have signals on the computer that light up when the input or output functions are energized, respectively. Computer controlled as well as non-computer controlled machines have white 120V control power terminal strips. This will indicate power supply from the respective circuits.

Idec controllers also have lights on them for the input and output functions. You can easily find out which circuits are failing by watching the lights turn on or off. Compare the lights on the IDEC controller to the electrical diagram to determine what systems are being affected.

IF THE POWER STOPS DURING NORMAL OPERATIONS:

1. Check that the input power disconnect switch is not turned off.
2. Check that all of the emergency stop buttons are in the normal position.
3. Lock Out and Tag Out the main power source.
4. Turn the panel disconnect switch in the off position, open the electrical panel door.
5. Observe the disconnect switches. Look for loose or broken wires at the disconnect then at all of the components.
6. Check for continuity of all fuses with an OHM meter.
7. Check motor overloads by pressing each white button (usually at the bottom of the panel in SEQUENCE, if one is tripped there will be a slight resistance to touch and a click as it is reset.

DANGER

The following checks will require the electrical panel to be energized these trouble shooting checks MUST BE PERFORMED BY A QUALIFIED ELECTRICAL TECHNICIAN.

1. Remove lock and tag outs on the main power sources

2. Manually close disconnect switches and energize the control circuit or transformer with its respective switch. Observe that the numbers 1, 3 & 4 are lit on the white lighted terminal strip.
3. This tells you that there are no overloads or emergency stops tripped. On computer controlled units, make sure that the POWER and RUN lights are lit at the lower left of the computer.
4. Most electrical problems are related to mechanical malfunction (i.e. stuck motors, jammed chain, non-tripped limit switches, etc...) The most common failure is an improperly adjusted limit switch. To check a limit switch, manually operate the limit switch. If the computer terminal strips lights, the switch needs to be re-adjusted. For more information on the limit switch see the manufactures information at the end of this manual.
5. If a solenoid valve is suspected, and not cleared in the air checks section mentioned previously, it can be electrically jumped to check operation.



NOTES





Notes:





Notes:





<http://www.kvalinc.com>



Contacting KVAL

Phone and Fax:

In the U.S and Canada, call (800) 553-5825 or fax
(707) 762-0485

Outside the U.S. and Canada, call (707) 762-7367
or fax (707) 762-0485

Email: service@kvalinc.com

<http://www.kvalinc.com>

Customer Service

Mailing address:

Customer Support Department

Kval Incorporated

825 Petaluma Boulevard South

Petaluma, CA 94952
